

# ROD 400 Series

Incremental Rotary Encoders for separate rotor coupling

- Outer Diameter 56 mm
- Length 32.5 mm/45.5mm
- Shaft Diameter 8.0 mm

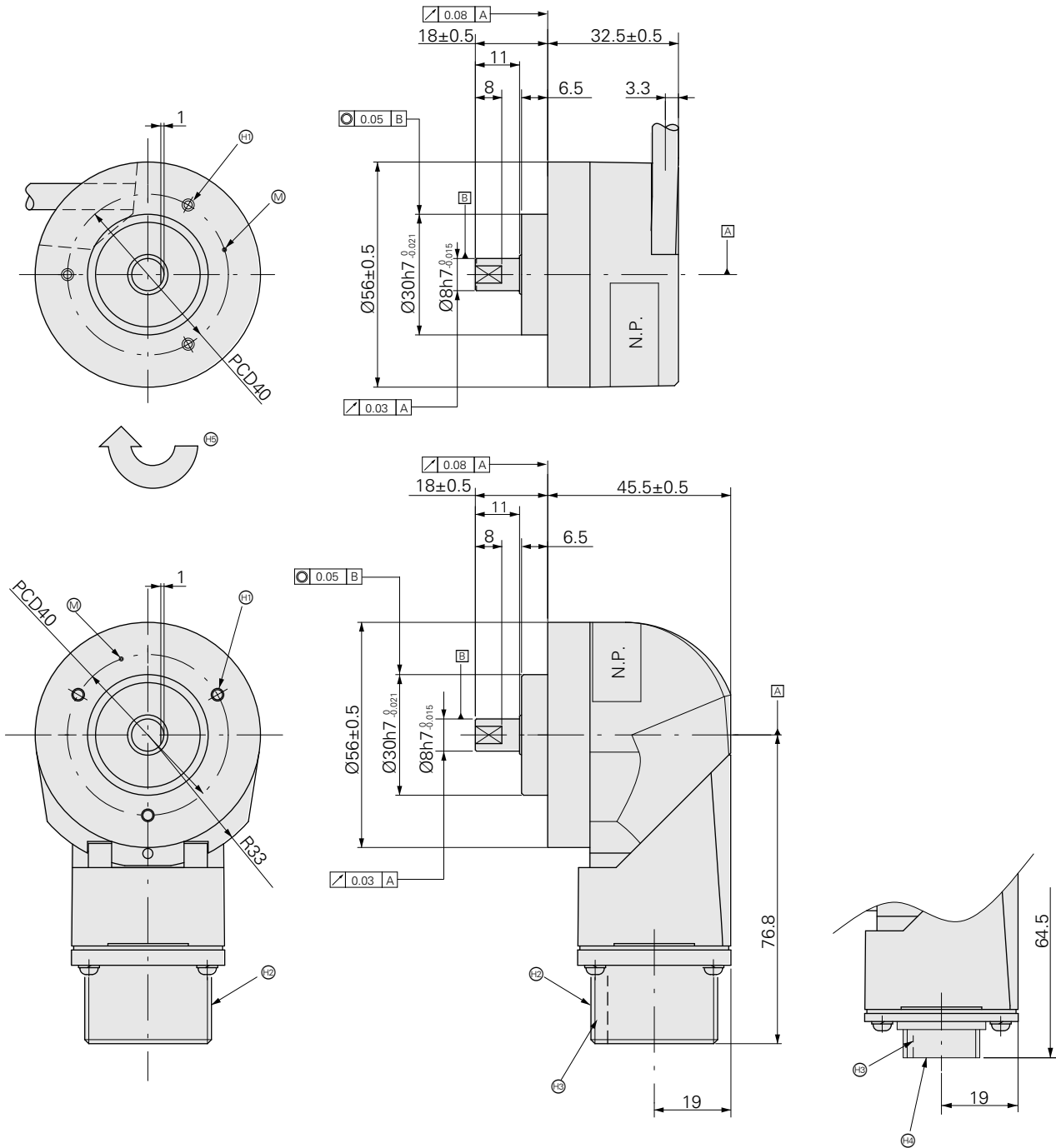

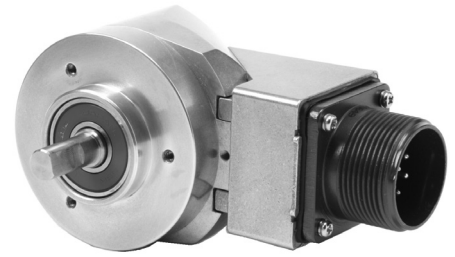

Dimensions in mm



Tolerancing ISO 8015

- Ⓜ = Measuring point for operating temperature
- Ⓧ = 3-M3, Depth 6, Equally Spaced
- Ⓩ = Flange socket MS3102E20-29P(Equivalent)
- Ⓚ = Key
- Ⓛ = Flange socket RM15WTRZ-10P
- Ⓝ = Direction of shaft rotation for output signals as per the interface description

	ROD 420	ROD 430	
<b>Incremental signals</b>	 TTL - C <sup>1)</sup>	 HTL - C <sup>1)</sup>	 HTLs <sup>2)</sup> - C <sup>1)</sup>
Output pulse * (Accuracy Class)	100 <sup>(l)</sup> 200 <sup>(l)</sup> 300 <sup>(l)</sup> 500 <sup>(l)</sup> 512 <sup>(l)</sup> <b>600<sup>(l)</sup></b> 900 <sup>(l)</sup> 1000 <sup>(l)</sup> <b>1024<sup>(l)</sup></b> 1200 <sup>(l)</sup> 2500 <sup>(l)</sup> 4096 <sup>(l)</sup> 5000 <sup>(l)</sup> 10000 <sup>(ll)</sup>		
Scanning frequency Edge separation <i>a</i>	≤ 300 kHz ≥ 0.41 μs	≤ 200 kHz ≥ 0.62 μs	
<b>System accuracy</b>	Accuracy Class I : ±1/10 SP Accuracy Class II : ±1/5 SP		
<b>Power supply</b> <b>Current consumption</b> without load	5V ± 10% ≤ 70 mA	10.8V to 26.4V ≤ 70 mA	
Output current	± 10 mA	± 20 mA	≤ 40 mA
Electrical connection	<ul style="list-style-type: none"> <li>• <b>Cable 1m, without connector</b></li> <li>• 17-pin MS3102E-20-29P flange socket, radial</li> <li>• 10-pin RM15WTRZ-10P flange socket, radial</li> </ul>		
<b>Shaft</b>	Solid shaft D = 8 mm		
<b>Mech. permissible speed n</b>	≤ 6000 min <sup>-1</sup>		
<b>Starting torque</b> (at 20°C)	≤ 0.007 Nm		
<b>Moment of inertia of rotor</b>	3.0 · 10 <sup>-6</sup> kgm <sup>2</sup>		
<b>Shaft load</b>	Axial : 20 N Radial: 30 N		
<b>Vibration</b> 25 to 2000 Hz <b>Shock</b> 6 ms	≤ 100 m/s <sup>2</sup> (JIS C 60 068-2-6, EN 60 068-2-6) ≤ 1000 m/s <sup>2</sup> (JIS C 60 068-2-27, EN 60 068-2-27)		
<b>Max. operating temp.</b> <b>(Ambient Temperature)</b>	90°C (85°C)		
<b>Min. operating temp.</b>	For rigid configuration : -20°C For frequent flexing : -10°C		
<b>Protection</b> EN 60 529	IP64 (IP66 when shaft is stationary)		
<b>Mass</b>	Cable                      Approx. 0.2 kg (without cables) Flange socket            Approx. 0.4 kg		

**Bold** : preferred versions

\* Please select when ordering.

<sup>1)</sup> Bypass capacitor is connected to FG.

<sup>2)</sup> Without inverse signal

# Mounting Accessories

**Mounting flange for ROD 400 series**  
ID 728 586-01

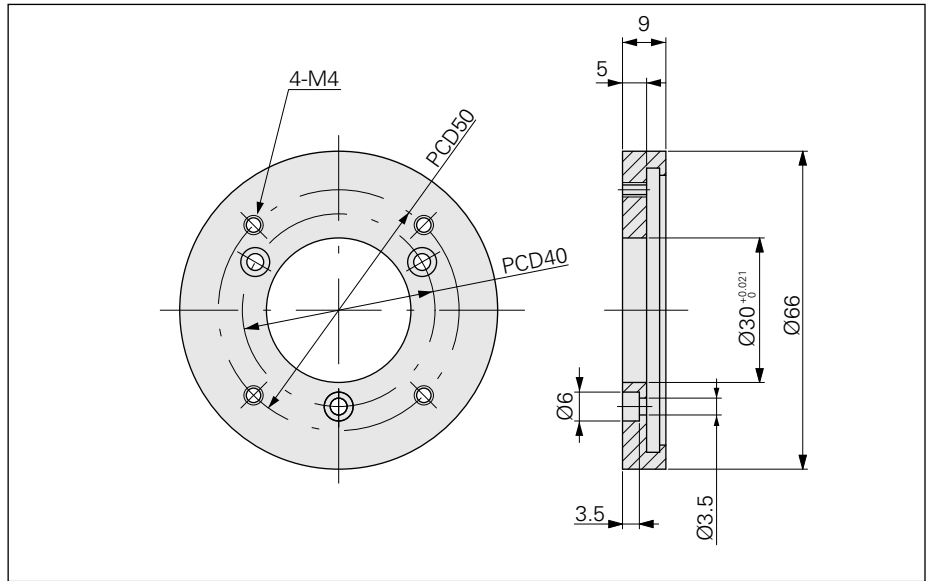
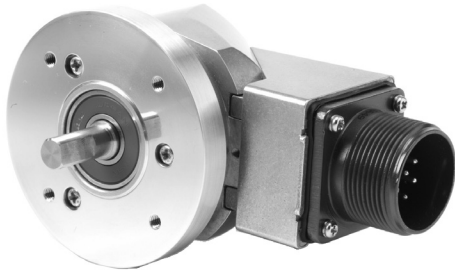

# Rotor Couplings

	for ROD 400 series
	C 22
Hub bore	8/8 mm
Galvanic isolation	-
Kinematic transfer error*	$\pm 20''$
Torsional rigidity	$225 \frac{\text{Nm}}{\text{rad}}$
Max. torque	0.98 Nm
Max. radial offset $\lambda$	$\leq 0.2 \text{ mm}$
Max. angular error $\alpha$	$\leq 1.5^\circ$
Max. axial motion $\delta$	$\leq 0.3 \text{ mm}$
Moment of inertia (approx.)	$2.5 \cdot 10^{-6} \text{ kgm}^2$
Permissible speed	$20000 \text{ min}^{-1}$
Mass	30 g

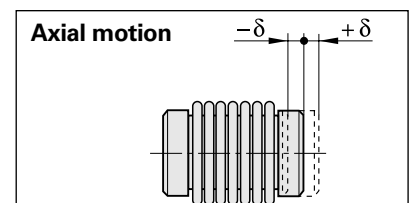
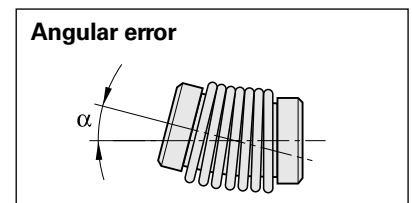
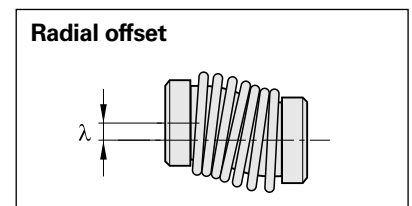

\*With radial misalignment  $\lambda = 0.1 \text{ mm}$ ,  
angular error  $\alpha = 0.15 \text{ mm}$   
over  $100 \text{ mm} \pm 0.09$ , valid up to  $50^\circ \text{C}$

**Rotor coupling C 22**  
for ROD 400 series  
ID 731 375-01

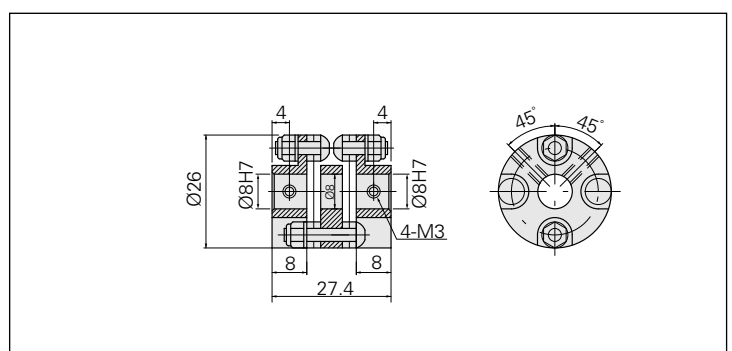



# Connecting Elements and Cables

## Connecting Cables

### Standard

Cable diameter 6.5 mm		
Connector	Cable Specification	
10-pin RM15TP-10S	4x 2x 0.18 mm <sup>2</sup>	736060-xx
17-pin MS3106B-20-29S MS3057-12A	4x 2x 0.18 mm <sup>2</sup>	736061-xx

### Waterproof or environment resistant

Cable diameter 6.5 mm		
Connector	Cable Specification	
10-pin RM15WTPZ-10S JR13WCC-xx	4x 2x 0.18 mm <sup>2</sup>	1172308-xx
Cable diameter 9.5 mm		
Connector	Cable Specification	
17-pin MS3106F-20-29S	4x 2x 0.18 mm <sup>2</sup>	1279245-xx

## Mating Connectors

Mating connector	Type-Name	ID Number
10-pin, Connector, Standard	RM15TP-10S	721636-02
10-pin, Connector, Waterproof	RM15WTPZ-10S	1105835-01
10-pin, Clamp, Waterproof	JR13WCC-10	1106395-01
17-pin, Connector, Standard	MS3106B-20-29S	721630-01
17-pin, Clamp, Standard	MS3057-12A	721627-01
17-pin, Combined Connector/Clamp unit, Environment resistant	MS3106F-20-29S	1105832-01

# Pin Layout

## TTL – C / HTL – C

10-pin RM15WTRZ-10P flange socket				17-pin MS3102E-20-29P flange socket									
		Power supply			Incremental signals						Other signals		
10-pin RM15WTRZ-10P flange socket		1	2	10	3	4	5	6	7	8	/	9	/
17-pin MS3102E-20-29P flange socket		H	K	T	A	N	C	R	B	P	M	/	D/E/F/G/J/L/S
		$U_P$	0V	FG	$U_{a1}$	$\overline{U}_{a1}$	$U_{a2}$	$\overline{U}_{a2}$	$U_{a0}$	$\overline{U}_{a0}$	0V	Vacant	Vacant
Cable Ø 6.5 mm 4x 2x 0.18 mm <sup>2</sup>		White	Black		Red	Pink	Olive	Blue	Yellow	Orange			
Cable Ø 9.5 mm 4x 2x 0.18 mm <sup>2</sup>		White	Black (White)		Red	Black (Red)	Green	Black (Green)	Yellow	Black (Yellow)			

Cable shield connected to housing;  $U_P$  = power supply; the color of twisted pair cable is shown in brackets

## HTLs– C / Open Collectors

10-pin RM15WTRZ-10P flange socket				17-pin MS3102E-20-29P flange socket									
		Power supply			Incremental signals						Other signals		
10-pin RM15WTRZ-10P flange socket		1	2	10	3	4	5	6	7	8	/	9	/
17-pin MS3102E-20-29P flange socket		H	K	T	A	N	C	R	B	P	M	/	D/E/F/G/J/L/S
		$U_P$	0V	FG	$U_{a1}$	0V	$U_{a2}$	0V	$U_{a0}$	0V	0V	Vacant	Vacant
Cable Ø 6.5 mm 4x 2x 0.18 mm <sup>2</sup>		White	Black		Red	Pink	Olive	Blue	Yellow	Orange			
Cable Ø 9.5 mm 4x 2x 0.18 mm <sup>2</sup>		White	Black (White)		Red	Black (Red)	Green	Black (Green)	Yellow	Black (Yellow)			

Cable shield connected to housing;  $U_P$  = power supply; the color of twisted pair cable is shown in brackets

# HEIDENHAIN

[www.heidenhain.co.jp](http://www.heidenhain.co.jp)

HEIDENHAIN K.K.

Hulic Kojimachi Bldg., 9F  
3-2 Kojimachi, Chiyoda-ku,  
Tokyo 102-0083 Japan

+81 (0)3 3234 7781

+81 (0)3 3262 2539